



# ACM-3401/ACM-3411



- 1/3" Micron Progressive Scan CMOS
- Day and night function with Mechanical IR Cut Filter (ACM-3411)
- Integrated f4.2mm / F1.8 Megapixel lens
- 0.5 Lux (ACM-3401) / 0.05 Lux (ACM-3411) at F1.8
- Selectable MPEG-4 / MJPEG compression
- Up to SXGA resolution at 8 FPS
- Multi-stream with variable frame rate in the same compression
- Two-way audio supported
- Hardware motion detection
- DC 12 V or Power over Ethernet (IEEE 802.3af) supported
- Surface and wall mount supported



- |                        |                       |
|------------------------|-----------------------|
| 1 Audio Input / Output | 3 DC 12 V Power Input |
| 2 Reset Button         | 4 Ethernet Port       |

## DIMENSION DIAGRAM

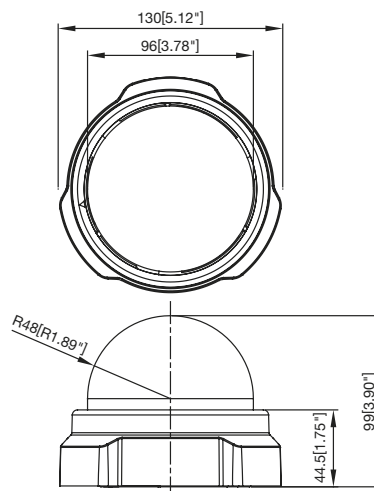

Unit: mm [inch]



# ACM-3401/ACM-3411

## PRODUCT SPECIFICATION

		ACM-3401	ACM-3411
Image	Device	Micron Progressive Scan CMOS	
	Size	1/3 inch	
	Effective Pixels	1280 x 1024	
Min. Scene Illumination	Color	0.5 Lux at F1.8 (30 IRE,MAX AGC)	Color mode automatically switched to B/W mode under 7 Lux
	B/W	N/A	0.05 Lux at F1.8 (30 IRE,MAX AGC)
	IR Sensitivity	N/A	from 700nm to 1100 nm
	CDS Sensor	N/A	Yes
Lens	Lens	f4.2 mm / F1.8	
	Viewing Angle	75° (Horizontal)	
Camera Angel Adjustment	X (Panning)	0° ~170°	
	Y (Tilting)	0° ~90°	
Synchronization	Sync. System	Internal	
Day/Night Functions	Mechanical IR Cut Filter	N/A	Yes
Functions	Motion Detection	Yes (3 Windows)	
	Electronic Shutter	1/10 ~ 1/2,000 sec. (60Hz); 1/10 ~ 1/2,000 sec. (50Hz)	
	Flickerless	1/120 sec. (60Hz); 1/100 sec. (50Hz)	
	BLC	Yes	
	AGC	Automatic (User defined)	
	White Balance	6 modes (AUTO,INDOOR1,INDOOR2,OUTDOOR1,OUTDOOR2, HOLD CURRENT,MANUAL) configurable	
S/N Ratio	S/N Ratio	Better than 44 dB	
Video Compression	Compression	MPEG-4 SP, MJPEG selectable	
	Picture Resolution	SXGA (1280x1024); HD 720 (1280x720); VGA (640x480)	
	Image Frame Rate	SXGA at 8 fps; HD720 at 10 fps; VGA at 30 fps	
Audio Input	Compression	8kHz, Mono, PCM	
	Audio Line Input	Unbalanced, 1.4Vp-p, 1Vrms, terminal block	
Audio Output	Compression	8kHz, Mono, PCM	
	Audio Line Output	Unbalanced, 1.4Vp-p, 1Vrms, terminal block	
External I/O	Reset Button	Factory default	
Casing	Mount Types	Surface / Wall (option)	
Network	Ethernet	Ethernet (10/100 Base-T), RJ-45 connector	
	Protocol	TCP, UDP, IP, HTTP, DHCP, PPPoE, RTP, RTSP,FTP,SMTP,DNS,DDNS,NTP,ICMP,IGMP,ARP,3GPP	
Software	Web Browser	Microsoft Internet Explorer 6.0 or above	
	SDK	ACTi SDK-10000	
	Security	Password protection: configured by the administrator	
Operating	Temperature	-10 °C ~ 50 °C (14 °F ~ 122 °F)	
Power	Power Requirement	PoE (IEEE802.3af) with Class 3	
	Power Consumption	3.3 W (DC 12 V); 4.3 W (PoE)	
Physical	Dimensions (øxL)	130 mm x 99 mm (5.12" x 3.90")	
	Weight	350 g (0.7 lb)	

## ORDERING INFORMATION

Model Name	D&N	DC 12V / PoE
ACM-3401		V
ACM-3411	V	V

## ACCESSORY OPTIONS

- Wall mount kit MTB-201-R0



MTB-201-R0

\* All specifications are subject to change without notice.  
 \* All brand names and registered trademarks are the property of their respective owners.